

Solenoid Operated Directional Valves



Applications

Solenoid operated valves differ from manually and hydraulically pilot-operated valves in that they are electrically controlled as opposed to using complex mechanical linkages or bulky hydraulic pilot lines to actuate the valve. Using solenoid valves can result in a much easier installation, with the resulting cost savings being an additional benefit.

Sun solenoid operated directional valves are used in circuits where 2-way, 3-way, and 4-way functions are required. Sun offers both direct acting and pilot operated, and are available in poppet and spool configurations.

- Pilot flow capacity valves, rated 0.25 gpm (1 L/min), are available in 2-way and 3-way functions.
- Full flow capacity valves, rated up to 12 gpm (45 L/min), are available in 2-way, 3-way, 4-way, and 6-way functions.
- High capacity pilot-operated valves, rated up to 120 GPM (480 L/min), are available in 2-way, normally open and normally closed versions.
- All full flow and high capacity versions are available with Sun's 77* series (round) solenoid/coil assemblies.
- Pilot flow capacity valves are also available with the smaller 760 series (square) solenoid/coil assemblies. (See figure 1 for an explanation).
- All assemblies have solenoid tubes that are fatigue rated for 5000 psi (350 bar) service, allowing these valves to be rated at 5000 psi (350 bar) on all ports.
- Sun poppet style valves have leakage rates of less than 10 drops per minute at 5000 psi (350 bar), when low leakage is a requirement.
- A unique 2-position 3-way poppet valve is available that can offer a circuit solution that typically requires the use of two 2-way poppet valves.

Sun solenoid coils are available in a variety of AC and DC voltages and various coil terminations.

- Sun coils are available with built in Arc Suppression Diodes, which limit damage to electrical switch contacts. Selected DC coils are available without arc suppression diodes.
- Unique, robust, and easy to use manual override options are available on all 760/77* series solenoid/coil assemblies.

Design Concepts, Features, and Circuit Considerations

Sun's Three Basic Types of Solenoid Cartridges

- Pilot flow valves (also referred to as Series P) are rated at 0.25 gpm (1 L/min), and are typically used to actuate other, larger, valves.
- Full flow valves (also, referred to as Series 1), are available in flow capacities up to 12 gpm (45 L/min).
- High capacity pilot-operated with capacity up to 120 GPM (480 L/min).

Pilot Flow Solenoid Valves

- Utilize the Series P cavity profiles (T-8A or T-9A). The T-8A versions can be installed directly into many of Sun's larger cartridges, including certain pressure control, flow control, logic and directional control valves.
- Are available with two solenoid/coil options:
 1. Original 760 series, low wattage solenoid/coil assemblies.
 2. 77*/790 solenoid/coil assemblies.

Full Flow Solenoid Valves

- Utilize the Series 1 cavity profiles (T-11A, T-13A, or T-31A).
- Are only available with the 77* series solenoid/coil assemblies.
- Weatherized solenoid assembly kits are available for most Series 1 full flow cartridges and pilot flow cartridges using the 77* series solenoid/coil assemblies. With the weatherization kit installed, the assembly can be rated to IP69K. (*This option protects the valve from the damage caused by harsh environments and high-pressure wash downs.*)

High Capacity Pilot-Operated Solenoid Valves

- Utilize the Series 1 through 4 cavity profiles (T-13A, T-5A, T-16A or T-18A).
- Are only available with the 77* series solenoid/coil assemblies.
- Are available with flow paths from port 1-2 and 2-1

(Figure 1 describes the solenoid assembly availability by cartridge size.)



Figure 1.

Shown disassembled and fully assembled, are two pilot flow valves with either Series P or Series 1 solenoid actuators, a full flow valve with a Series 1 solenoid actuator, and a Series 4 high capacity valve with Series 1 solenoid actuator.

Common Sun Solenoid Cartridge Features

- With the exception of high capacity valves, Sun solenoid valves are hydraulically balanced. *(The solenoid has to overcome friction bias spring force and flow forces in order to shift the valve.)*
- Sun offers a combination of direct acting and pilot-operated valves. Direct acting valves do not require minimum pilot pressure for valve actuation. Pilot operated valves offer the advantage of higher capacities.
- All solenoid actuators operate in a highly efficient, push fashion. (Only the DNDC 3-position, 4-way cartridge operates in a push/pull manner).
- Response time is measured in ms (milli-seconds) and is typically 50ms for Sun solenoid valves. *(Response time refers to the time lapse from the time voltage is applied to the coil to the point where pressure begins to change. Differing system configurations can cause this value to vary.)*
- Most Sun solenoid valves are available with a soft shift option that extends the shifting response time from 50 ms to a range of 150 to 300ms when the coil is energized, which can help minimize high pressure spikes that can occur when the valve is shifted. *(The soft shift option tends to reduce the valves capacity. Also, the time extension depends on a number of factors such as oil viscosity, temperature, flow rate, and system capacitance. Upon de-energizing, the solenoid shift time may be slightly longer.)*

Coil Options

Sun offers a variety of coil options for their solenoid operated valves. Coil voltage ranges and wattage are shown below in figure 2.

- The “43650 Form A DIN” connector is available on all coils.
- Coil terminations with IP ratings up to IP 69K are available for select coils.
- All coils come equipped with a transient voltage suppression (TVS) diode.
- AC coils include a full wave bridge rectifier.

(For a complete and up-to-date listing of all the voltages and coil terminations available, please refer to our website. For additional technical information on our coils, please refer to the Tech Tips for Sun Coils.)

Coil/Actuator Type	Coil Wattage	AC Voltage	DC Voltage
760 Series (Square)	12	115 & 230	6-48
77* Series (Round)	22	24 - 230	12-127
777 Series (Ex-Proof)	22	N/A	24

Figure 2.

Available coil voltage and wattage ranges.

Manual Overrides

Manual overrides are available for all Sun two position solenoid valves. (An exception is model DNDC 3-position, 4-way cartridge which is not available with manual overrides.)

- 760 solenoid/coil assemblies come equipped with a manual override button as a standard feature.
- 77* solenoid/coil assemblies are available with the following options:
 - No manual override
 - Manual override pin
 - Twist/Lock rotary style manual overrides
- 777 explosion proof solenoid/coil assemblies are available in the override pin (M version) or no manual override (X version)

Twist/lock Rotary Style Manual Override

- The twist/lock manual override is constructed of durable reinforced plastic.
- The weatherized design prevents contamination from external elements.
- Sun manual overrides feature an internal spring relief, that will not allow forced actuation of the valve if there is a physical obstruction present.
- Knob actuation requires minimal force.
- Actuation can easily be accomplished with a gloved hand.
- See Figure 3 for available styles.

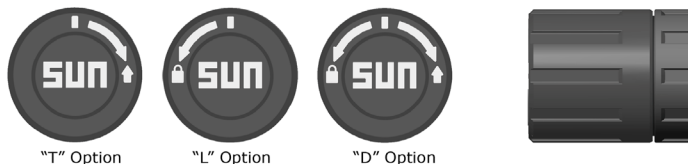

Kit Number	Option	Feature	Degrees of Rotation
991-225	T	Momentary Twist	CW 45°
991-226	L	Lock	CCW 45°
991-227	D	Momentary Twist and Lock	CW or CCW 45°

Figure 3.

Manual override options and features.

Low Leakage Poppet Style Valves

Two and Three Port, 2-Position, 2-Way and 3-Way - DTDA and DWDA

The DTDA (2-position, 2-way) and DWDA (2-position 3-way) are full flow poppet style valves. Performance parameters include:

- Extremely low leakage characteristics.
- Can be used in load holding applications.
- The DTDA is available in normally open and normally closed versions.
- In load holding applications, the circuit should be designed so that the de-energized state is the position that is holding the load.
- The DWDA has an all-ports-open cross over condition. If high flow potential exists, such as with an accumulator, the valve can malfunction during shifting. *(A flow-limiting orifice must be installed if this circuit condition exists.)*
- The DWDA can be used to take the place of two 2-position 2-way valves. (See Figure 4.)

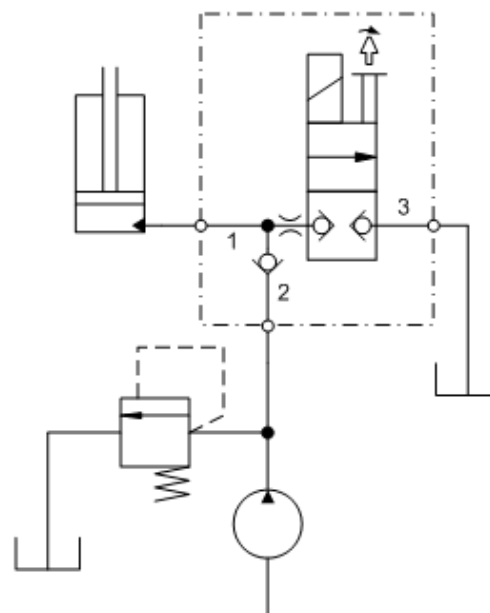

Figure 5.

An HDDA, with optional orifice, can be used in a common lift/lower single-acting cylinder circuit.

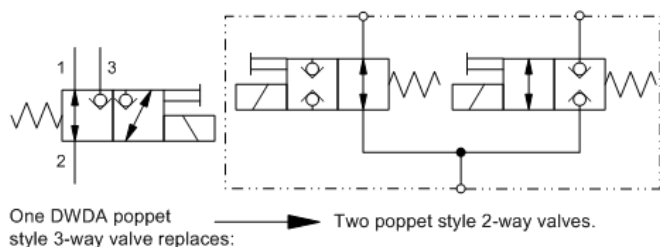

Figure 4.

A DWDA poppet style 3-way poppet valve can be used in low leakage applications that typically require two 2-way poppet valves.

Two port, 2-Position, 2-Way With Integral Check - HDDA

The hybrid HDDA full flow valve incorporates a poppet style valve with an integral check valve. Performance parameters include:

- The check allows free flow from port 2 to port 1
- The poppet controls flow between port 1 and port 3.
- This valve can be used in a circuit with a single acting cylinder to control motion and provide load holding. (See Figure 5.)

Two port, 2-Position, 2-Way with overlap - DTCA

The DTCA is a full flow poppet/spool valve. It combines the features of both valve styles but with a reduced capacity. This valve is very similar in function to the DTDA except it includes an overlap in the spool, while still maintaining a low leakage poppet style seat. The overlap restricts flow at the initial opening of the valve. Performance parameters include:

- The overlap characteristic is useful in cases where leakage occurs with a regular poppet valve when it is exposed to rapid pressure changes. This effect only occurs when the flow direction is from port 1 to port 2. *(The rapid pressure changes tend to slightly lift the poppet off the seat and allow a small amount of fluid to pass.)*
- Combining a spool and a poppet in one assembly, limits the amount of fluid that passes with minimal spool travel at initial opening.
- Leakage rates for this valve are the same as other Sun poppet valves.
- This valve is only available in a normally closed version.

Spool Style Valves

Two port, 2-Position 2 and 3-Way Pilot Capacity – DAAL, DBAL, DAAA, and DBAA

The DAAL (2-way) and DBAL (3-way) are pilot capacity spool type directional valves, and are actuated by the 77* series (round) solenoid/coil assembly which allows the wider variety of manual override options. The DAAA and DBAA are equivalent hydraulically, except they are actuated with the 760 series (square) solenoid/coil assembly. Performance parameters include:

- The DAAL and DAAA pilot directional valves can be installed directly into a T8-A cavity located in the hex body of a Sun main stage valve.
- The DBA* 2-position 3-way spools have a closed transition from one condition to another, resulting in a minimal loss of pilot pressure during shifting.
- All versions can be used independently; to control the pilot signal for larger pilot operated valves.
- A common application for the 2-way version is to control the vent port of a vented relief valve. *(When a DAAL is open, the relief would be at its vented pressure. Closing the DAAL allows the relief to function at its pre-adjusted setting.)* (See Figure 6.)

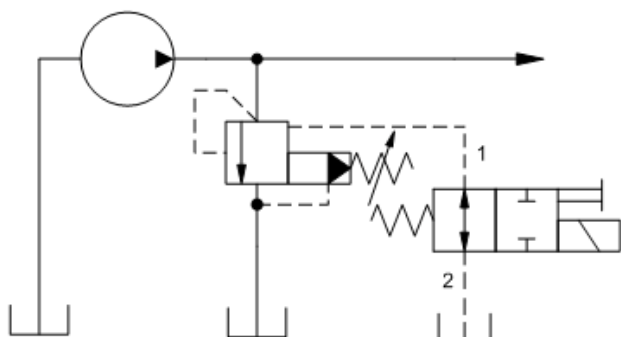

Figure 6.

A common application for a DAAL, pilot flow, 2-way valve, is to close or vent a ventable pilot operated relief valve.

Two port, 2-Position 2-Way - DLDA

The DLDA, full flow, 2-way, spool type directional valve is available in a normally open or a normally closed configuration. Performance parameters include:

- This valve can be used as a bi-directional switching element.
- Depending on the spool configuration, energizing the coil will allow fluid to either pass or be blocked (e.g. normally closed, or normally open).
- Figure 7 shows the DLDA can be used in a cylinder decompression application. *(Orifice placement, upstream of the valve, is critical in preventing valve saturation.)*

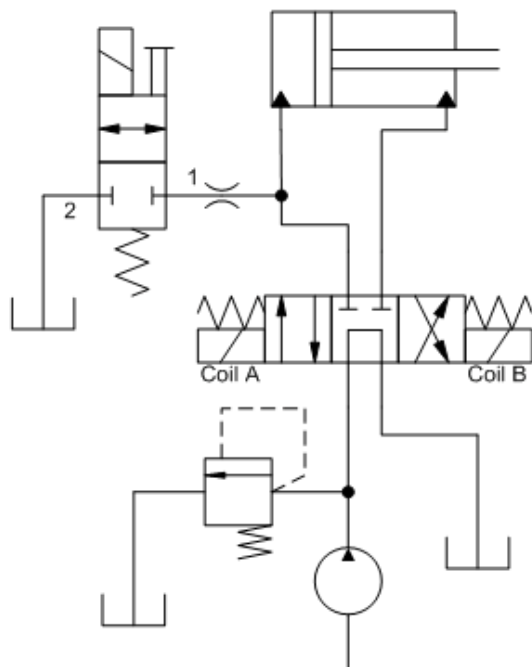

Figure 7.

A DLDA 2-way valve is used here to decompress the cap end of a large bore cylinder before reversing. The orifice should be sized based on the maximum pressure, compressed cylinder volume, and decompression time goal.

Three port, 2-Position 3-Way - DMDA

The DMDA, full flow, 3-way, spool type directional valve is available with port 1 normally open or normally closed. Performance parameters include:

- Open or closed transition spools are available.
- Normally open port 1 to 2, or normally open port 2 to 3 versions are available.
- The common port to both shift conditions for spools A, N, B, and R, is port 2.
- Spool P loops ports 1 and 3 together in the de-energized position.
- The closed transition spools (B and R) allow for clean transition from one position to another without any momentary cross metering. *(Valve capacity is reduced.)*
- A closed transition spool would be used where the pressure needs to be maintained in the primary circuit when shifting the valve from one condition to another.
- Two DMDAs can be used to create a 3-position, 4-way valve. *(Energizing each valve independently will allow the cylinder to extend or retract. Energizing both solenoids allows the cylinder to extend in regeneration mode.)* (See Figure 8.)

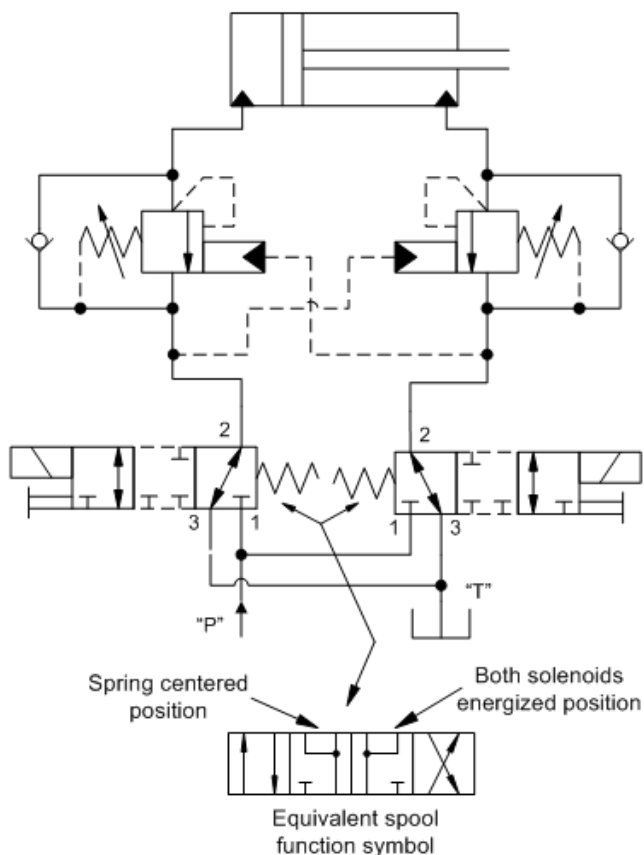

Figure 8.

Two DMDA, 3-way valves can replace a 3-position 4-way spool valve. Energizing both coils offers regeneration capability.

Four port, 2-Position, 4-Way - DNDA

The DNDA is a full flow (10 gpm [40 L/min.] nominal capacity), 2-position, 4-way directional valve. Performance parameters include:

- Ten spool configurations are available. (See Figure 9a.)
- Cross-metering between ports can occur during shifting. (*All spool transitions are partially open.*)
- The “R” spool can be used for cylinder regeneration, but performance limits must be considered. (*Valve capacity may be exceeded with certain cylinder ratios.*)
- The “Y” spool is a unidirectional motor spool, allowing the motor to free wheel in the spring offset position. (*Both motor ports and the tank port are connected together.*) In the energized condition, oil is directed to rotate the motor and the discharge flow is directed to tank.

SPOOL OPTIONS			
Code	Symbol	Code	Symbol
C		R	
T		E	
H		N	
Y		U	
D		L	

Figure 9a.

DNDA spool options shown with transition conditions.

Four port, 2-Position, 4-Way - DNCA

The DNCA is a full flow (8 gpm [30 L/min.] nominal capacity), 2-position, 4-way directional valve, similar to DNDA except as noted in the following performance parameters:

- All spool transitions are closed with no cross-metering between ports during shifting.
- The ten available DNCA spool configurations are shown in Figure 9b.
- Nominal flow capacity is somewhat reduced (e.g. from 10 gpm [40 L/min.] down to 8 gpm [30 L/min.]).
- The previously stated notes for the DNDA “R” and “Y” spools apply to the DNCA “S” and “Z” spools respectively.

SPOOL OPTIONS			
Code	Symbol	Code	Symbol
A		S	
B		T	
C		W	
J		X	
L		Z	

Figure 9b.

DNCA spool options shown with transition conditions.

Four port, 3-Position, 4-Way - DNDC

The DNDC is a full flow, spring centered, 3-position, 4-way directional valve. Performance parameters include:

- Eight spool transition/center condition configurations are available. (All offset, or shifted, conditions are identical.) (See Figure 10.)
- In differential flow applications, the higher return flow should be directed from port 2 to port 1 to take advantage of the lowest pressure drop. (See Figure 11.)
- The DNDC cartridge is not available with the soft shift option.
- There are no manual override options available.

Six port, 2-Position, 6-Way - DNDY

The unique DNDY cartridge is a 2-position, 6-way, directional valve. Performance parameters include:

- Nominal flow rating is 5 gpm, but varying system pressures can make the actual value vary from 2-10 gpm (8-40 L/min)
- This cartridge can be used to swap the work ports between two actuators. (See Figure 12.)
- The ability to select two different circuits being supplied by one pump represents another application. (See Figure 13.)

SPOOL OPTIONS			
Code	Symbol	Code	Symbol
A		R	
B		T	
C		W	
H		Y	

Figure 10.
DNDC spool options shown without transition conditions.

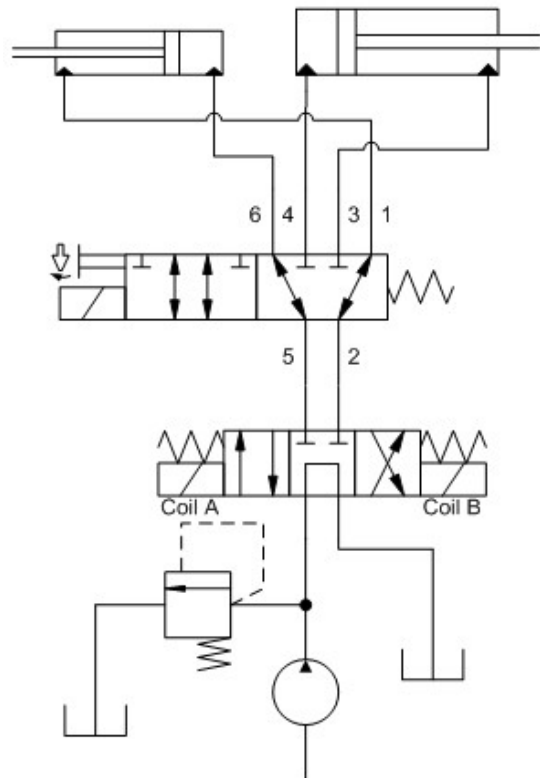

Figure 12.
A single 4-way valve can control two separate actuators using a DNDY 6-way valve as a selector.

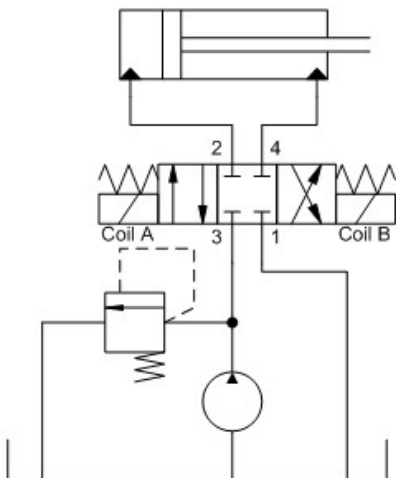

Figure 11.
Here, a DNDC 4-way valve is connected so that the higher differential flow will pass from port 2 to 1.

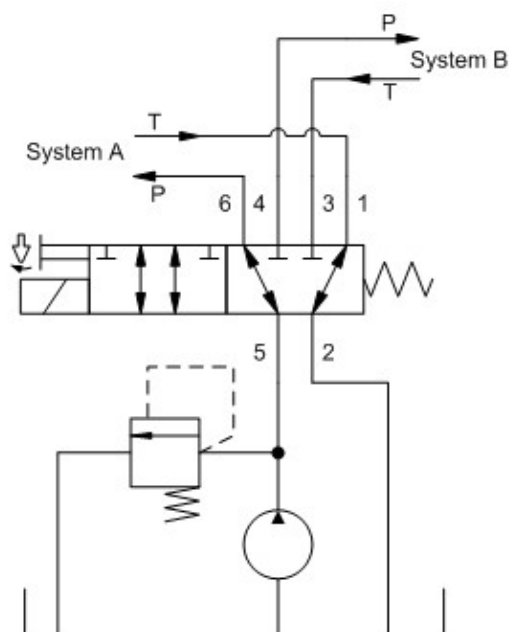

Figure 13.

The DNDY in this circuit is being used to select between two different output circuits, supplied by a single pumping power supply.

Performance parameters include:

- 4 different cartridge sizes with flow from 15 to 120 GPM (60L/Min. to 480 L/Min.)
- Full free reverse flow from the opposite port to the controlled port
- Pressure drop is the same for all flow path connections
- Response time is under 50 milliseconds
- Low energy consumption
- Manual override options available

Additional Application Notes

Soft Shift Solenoids:

- When using soft shift solenoids, it is recommended that inlet flow be routed to port one. If port one is routed to tank then a check valve is required to keep the oil from draining out of the solenoid tube. *(Oil must be maintained in the solenoid tube for the soft shift effect to occur.)*

Selection of a poppet or spool style valve:

- Before selecting either a poppet or spool style valve, the leakage that the application can tolerate must be considered.
 - Full flow poppet style valves have low leakage rates, typically less than 10 drops per minute at 5000 psi (350 bar). *(They can be used in load holding applications.)*
 - Full flow spool style valves can have leakage rates of 10in³ (160cc) per minute at 3000 psi (210 bar).
 - Pilot capacity spool valves also have low leakage rates, less than 10 drops per minute at 5000 psi (350 bar).

Performance limits:

- The performance limits charted on the individual product pages need to be checked very carefully. *(If a valve is chosen based on pump capacity, certain circuit conditions can create flows that are much greater than pump flow.)*
 - Exceeding the performance limit may prevent the spool/poppet from reaching its fully shifted condition.
 - An accumulator can be a source for high instantaneous flow rates, causing the flow rate in the circuit to exceed the valves capacity, and establish the need for the installation of a flow-limiting orifice in the system.
 - ➔ The orifice should be placed so as not to be concentric with the axis of the cartridge. *(The emerging oil jet from the orifice has the potential to destabilize the valve.)*

Please note: Sun solenoid valves are designed for use with mineral based hydraulic fluid. (The use of other fluids may cause the valve not to function as intended.)

2-Position, 2-Way, Flow Path 1-2 and 2-1 - DF*A and DF*B

The DF** Family are 2-position, 2-way, high capacity valves. These cartridges are two-stage poppet type valves driven by a pilot-operated solenoid. The combination of the poppet and the pilot-operated solenoid make these valves insensitive to solenoid stroke limitations.

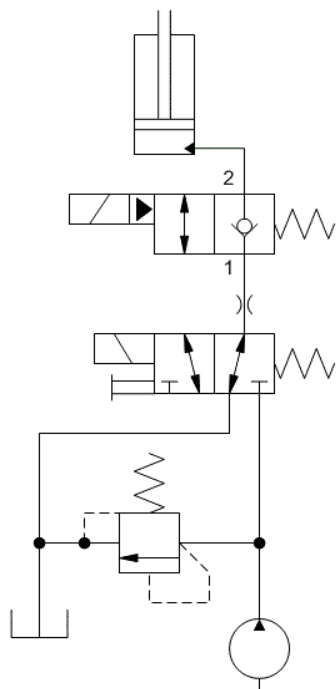

Figure 14.

The DF*B in this circuit is being used to lift a cylinder in the normal position, hold the load, and lower the cylinder when energized. An orifice could be used to control the same lift/low flow; or a free flow nose-to-side check valve with bypass orifice if one of the two flows needs to be faster.

Solenoid Operated Cartridge Valves Overview

Function	Description	Nominal Capacity	Model	Cavity	Symbol
2 Way	Poppet	10 gpm (40 L/min.)	DTDA	T-13A	<p style="text-align: center;">C-Spool H-Spool</p>
2 Way	Poppet - Soft Shift	4 gpm (15 L/min.)	DTDAS	T-13A	<p style="text-align: center;">C-Spool H-Spool</p>
2 Way	Spool	.25 gpm (1 L/min.) .25 gpm (1 L/min.) 12 gpm (45 L/min.)	DAAA DAAL DLDA	T-8A T-8A T-13A	<p style="text-align: center;">C-Spool H-Spool</p>
2 Way	Spool - Soft Shift	.25 gpm (1 L/min.) 7.5 gpm (30 L/min.)	DAALS DLDAS	T-8A T-13A	<p style="text-align: center;">C-Spool H-Spool</p>
2 Way	Poppet, High Capacity, Flow 1 to 2	15 gpm (60 L/min.) 30 gpm (120 L/min.) 60 gpm (240 L/min.) 120 gpm (480 L/min.)	DFCA DFDA DFEA DFFA	T-13A T-5A T-16A T-18A	<p style="text-align: center;">X-Control, C-Poppet X-Control, H-Poppet</p>
2 Way	Poppet, High Capacity, Flow 2 to 1	15 gpm (60 L/min.) 30 gpm (120 L/min.) 60 gpm (240 L/min.) 120 gpm (480 L/min.)	DFCB DFDB DFEB DFFB	T-13A T-5A T-16A T-18A	<p style="text-align: center;">X-Control, C-Poppet X-Control, H-Poppet</p>

Solenoid Operated Cartridge Valves Overview (Continued)

Function	Description	Nominal Capacity	Model	Cavity	Symbol
2 Way	Poppet, after check	10 gpm (40 L/min.)	HDDA	T-11A	
2 Way	Poppet, with Overlap	6 gpm (23 L/min.)	DTCA	T-13A	
3 Way	Poppet	7.5 gpm (30 L/min.)	DWDA	T-11A	
3 Way	Spool	.25 gpm (1 L/min.) .25 gpm (1 L/min.) 12 gpm (45 L/min.)	DBAA DBAL DMDA	T-9A T-9A T-11A	
3 Way	Spool - Soft Shift	.25 gpm (1 L/min.) 5 gpm (20 L/min.)	DBALS DMDAS	T-9A T-11A	
4 Way	2 Position	10 gpm (40 L/min.)	DNDA	T-31A	
4 Way	2 Position - Soft Shift	4 gpm (15 L/min.)	DNDAS	T-31A	
4 Way	2 Position - Closed Transition	8 gpm (30 L/min.)	DNCA	T-31A	

Solenoid Operated Cartridge Valves Overview (Continued)

Function	Description	Nominal Capacity	Model	Cavity	Symbol
4 Way	3 Position	5 gpm (20 L/min.)	DND C	T-31A	
6 Way	2 Position	5 gpm (20 L/min.)	DND Y	T-61A	
6 Way	2 Position - Soft Shift	5 gpm (20 L/min.)	DND YS	T-61A	